



## Adaptive Neuro-Fuzzy Inference System for Enhanced Load Frequency Control in Interconnected Power Systems

Nikunj J Dhimmar<sup>1\*</sup> and Ami T Patel<sup>1</sup>

<sup>1</sup>Department of Electrical Engineering, Government Engineering College, Bharuch, Gujarat, India

\*Corresponding author. Email address: [nikunj206@gmail.com](mailto:nikunj206@gmail.com)

Volume 6, Issue 14, Aug 2024

Received: 15 June 2024

Accepted: 25 July 2024

Published: 15 Aug 2024

doi: [10.48047/AFJBS.6.14.2024.10005-10015](https://doi.org/10.48047/AFJBS.6.14.2024.10005-10015)

### Abstract

The design and analysis of a Neuro-Fuzzy controller, based on the Adaptive Neuro-Fuzzy Inference System (ANFIS) architecture, were conducted to regulate frequency and power deviations in interconnected areas. Imbalances between supply and demand result in deviations from the nominal frequency, necessitating a rapid and precise controller. The ANFIS-based controller, offering a straightforward structure, continuously monitors operating conditions and adjusts settings optimally. By replacing traditional Proportional-Integral (PI) and Fuzzy Logic (FL) controllers, the ANFIS controller demonstrates improved performance in handling non-linearities. Simulation results indicate effective damping of frequency deviations, achieving steady-state values with settling times reduced from 44 to 10 seconds. Additionally, overshoot is minimized from 0.050 pu to 0.020 pu, and tie line power fluctuations are significantly lowered. These findings highlight the ANFIS-based Neuro-Fuzzy controller's ability to maintain system stability and reliability.

**Key words:** ANFIS, Automatic generation control, fuzzy logic, Load frequency control, Neuro Fuzzy

### 1 Introduction

The system must meet the load demand and the system frequency must be constant in order to maintain the power system efficient, economical, and dependable operation. In light of it, Automatic Generation Control (AGC) is crucial to the system's sustainability. Frequency at or very near the necessary nominal value and continue the planned transfer of authority between the connected regions to the ideal values. However, the load frequency is used to group these assignments together. Load Frequency Control (LFC), which is made up of various control mechanisms which are carried out at different timeframes throughout the system [1].

AGC aims to maintain a steady load frequency, balance tie line flow, distribute load among generators, and regulate in accordance with the timetable. It controls how power moves between different places [2].

Automatic generation control is a significant problem in a mass power system, where a large number of equipment are connected to one another and power is supplied via an Ethernet connection. The system frequency is changed by the difference between the amount of power generated and the amount of demand, which is very undesirable. If the generator's excitation is maintained, the reactive power need will be contested; otherwise, the bus voltage will drop below the allowable limit. The main control method is to maintain the voltage and frequency

within their designated limits while producing and delivering power in the grid system as cheaply and noticeably as possible [3].

Automatic Generation Control (AGC) is used in linked power systems to regulate the power imbalance between generating units and load centres. This Maintaining each area system is necessary to achieve equity in frequency by maintaining the tie line's power near the schedule value by controlling the production of real power alternators in relation to the demand for different loads throughout time [4].

AGC maintains the tie-line power flow and system frequency during minor disturbances, and the deregulation of the power sector has altered the structure of conventional power structure. The quantity of autonomous entities like as distribution firms, generation corporations (GENCOs), transmission firms and distribution businesses (DISCOs) Independent system operators (ISOs) and TRANSCOs have been vying for customers' business in the power sector [5].

Operation of the interconnected systems is only successful when total generation equals total load plus losses. Unwanted attempts are caused by variations in the frequency, net power interchange, and load demand, which all affect system performance. In thermal power generation, the output of mechanical power is used to control the power output from the generators. With a steam turbine, the mechanical power output can be adjusted by opening and closing the steam valve movement. Since the load in a power system is constantly fluctuating, in a controlled area, at least one generator needs to react to the load variation in order to sustain the scheduled frequency in a steady state. as well as the steam valve closing [6].

System frequency and the stable operation of a power system (PS) are closely related. For a PS to operate satisfactorily, the frequency must be maintained constant. This is achieved by matching the total power generation to the load. losses plus demand always. However, the need for load on The PS fluctuates minutely and complexly. This results in life of variations in generation-load. Such an unequal distribution of power flows into or out of a synchronous generator's rotor, causing variations in area frequency and, consequently, generator speed as well as tie-line power across adjacent regions. Without command, Maintaining the balance between power generation and consumption it is not feasible [7].

In recent years, the power system has undergone restructuring to become more independent, competitive, and vertically monopolistic. The government has a position in the vertical structure. Monopoly position in overseeing all sectors, such as power production firms' distribution firms, transmission corporations, and generation companies' businesses (DisCos). New engineering fields are created by contracts between the participants in the power market under the management of the Independent System Operator (ISO) [8].

The focus of Automated Generation Control (AGC) in interconnected power systems is on maintaining system frequency within predetermined bounds around the nominal value in order to maintain the scheduled power exchange between the interconnected regions and to maintain the most economical generation for each unit degree. There are studies on AGC of isolated and connected systems in the body of previous literature [9].

The primary goals of the power system utility are to economically and competently generate, transmit, distribute, and control electrical power while maintaining a steady supply of electricity for its customers in a satisfactory quality. Automatic generation control, or AGC, is essential to the power system's successful functioning and the delivery of high-quality power [10].

Four equal-importance components make up a typical power system: generation, transmission, distribution, and load. The effectiveness of the production, transmission, and Distribution networks rely heavily on the customer or the burden attached to it. In a typical system, the load fluctuates, both periodically and from one location to another. Customers are linked at various periods, which affects the power equilibrium framework. Because of this, the system's demand is not continuous. The associated loads are changing at random. This causes stochastic variables to be used to model the loads [11].

In an interconnected power system, the frequency and tie-line power interchange fluctuate in tandem with the random variations in the load demand. Fundamentally, the LFC addresses the issue of an immediate discrepancy between supply and demand for force in motion. The purpose of LFC, or load frequency control aim to reduce the short-term fluctuations in these factors and to make sure their values are zero in their steady state [12].

In a steady state power system, the phase angle difference between generators is kept close to the equilibrium point. The imbalance between mechanical and electrical torques during disturbances will cause frequency oscillation and energy communication between the groups of generators. The fluctuations could result in a loss of synchronization and maybe system islanding if Damping is insufficient [13].

## 2 Material and methodology

### 2.1 AGC in Interconnected power system

Consider the interconnected system shown in Figure 1. It consists of two areas connected by a tie line of reactance  $X_{tie}$ . For load-frequency studies, each area may be represented by an equivalent generating unit exhibiting its overall performance. Such composite models are acceptable since we are not concerned about inter machine oscillations within each area [14]. [10]

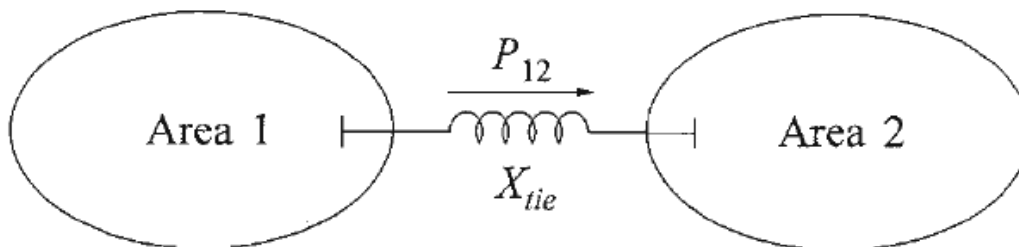

Figure 1 Two area system

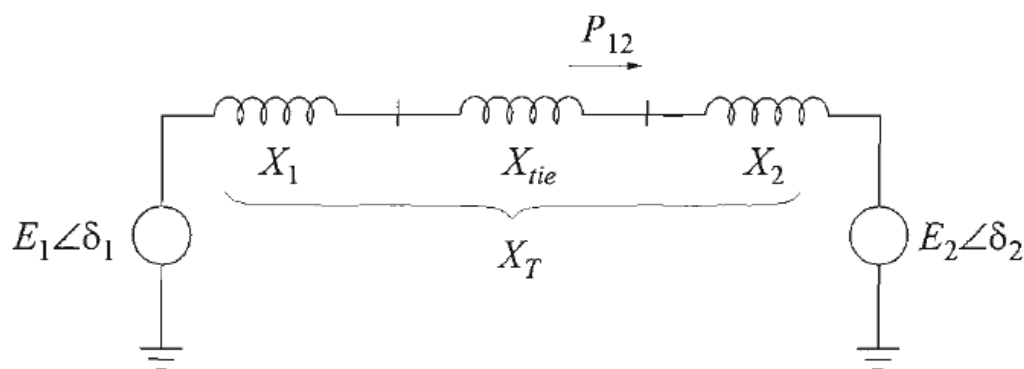

Figure 2 Electrical equivalent

Figure 2 shows the electrical equivalent of the system, with each area represented by a voltage source behind an equivalent reactance as viewed from the tie bus. The power flow on the tie line from area 1 to area 2 is

$$P_{12} = E_1 E_2 \sin(\delta_1 - \delta_2) \tag{1}$$

Linearizing about an initial operating point represented by  $\delta_1 = \delta_{10}$  and  $\delta_2 = \delta_{20}$

We have

$$\Delta P_{12} = T \Delta \delta_{12} \tag{2}$$

Where  $\Delta \delta_{12} = \Delta \delta_1 - \Delta \delta_2$  and T is the synchronous torque coefficient is given by

$$T = \frac{E_1 E_2 \cos(\delta_{10} - \delta_{20})}{X_T} \tag{3}$$

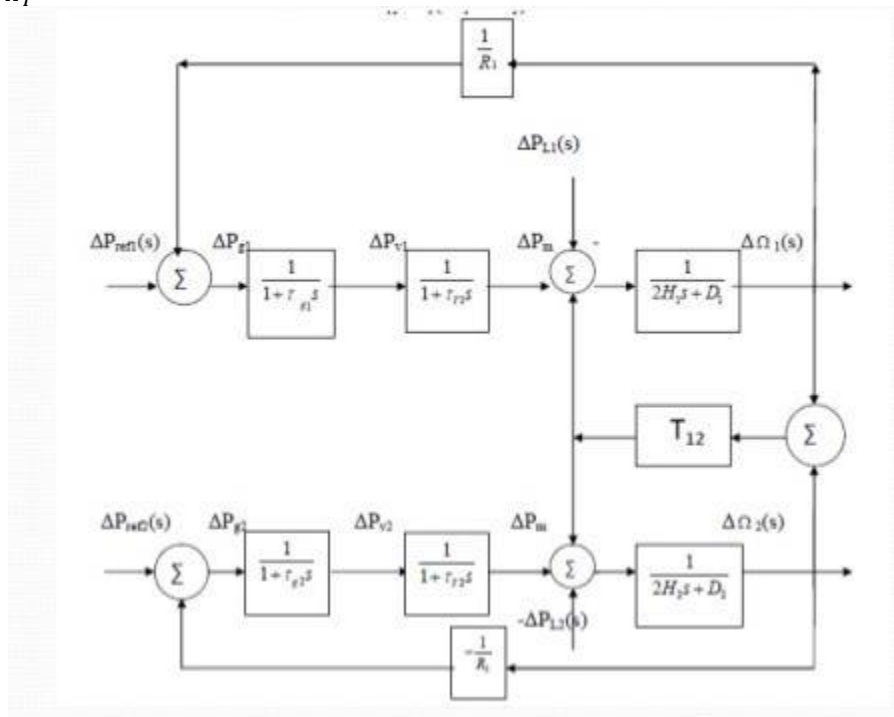

Figure 3 Block diagram of Two area system with only primary speed control

The block diagram representation of the system is shown in Figure 3 with each area represented by an equivalent inertia M, load-damping constant TPS turbine, and governing system with an effective speed droop R. The tie line is represented by the synchronizing torque coefficient T. A positive  $\Delta P_{12}$  represents an increase in power transfer from area 1 to area 2. This in effect is equivalent to increasing the load of area 1 and decreasing the load of area 2; therefore, feedback of  $\Delta P_{12}$  has a negative sign for area 1 and a positive sign for area 2.

The steady-state frequency deviation ( $f - f_0$ ) is the same for the two areas. For a total load change of  $\Delta P_L$

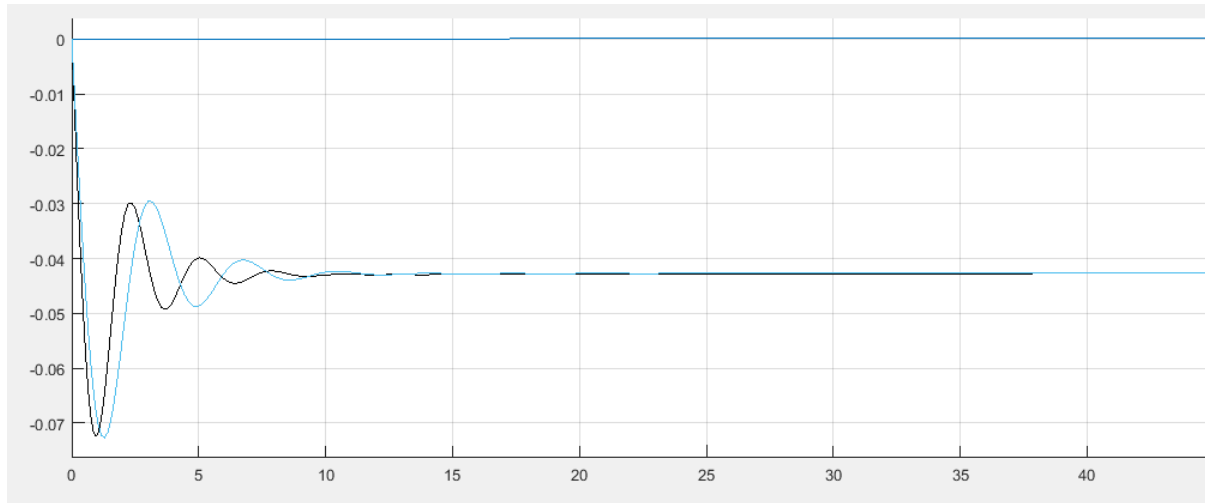

Figure 4 Steady state frequency deviation for two area system due to primary control

$$\Delta f = \Delta W_1 = \Delta W_2 = -\frac{\Delta P_L}{\frac{1}{R_1} + \frac{1}{R_2}} + (D_1 + D_2) \tag{4}$$

Consider the steady state values following an increase in area 1 load by  $\Delta P$ . For area 1, we have

$$\Delta P_{m1} - \Delta P_{12} - \Delta P_{L1} = \Delta f D_1 \tag{5}$$

And for area 2,

$$\Delta P_{m2} - \Delta P_{12} - \Delta P_{L1} = \Delta f D_2 \tag{6}$$

The change in mechanical power depends on regulation. Hence

$$\Delta P_{m1} = -\frac{\Delta f}{R_1} \tag{7}$$

$$\Delta P_{m2} = -\frac{\Delta f}{R_2} \tag{8}$$

Substitution of equation 7 in equation 5 and equation 8 in equation 6 yields

$$-\Delta P_{12} - \Delta P_{L1} = \frac{\Delta f}{D_1 + \frac{1}{R_1}} \tag{9}$$

$$-\Delta P_{12} - \Delta P_{L1} = \frac{\Delta f}{D_2 + \frac{1}{R_2}} \tag{10}$$

Solving equations 9 and 10, we get

$$\Delta f = \frac{\Delta P_{L1}}{\left(D_1 + \frac{1}{R_1}\right) + \left(D_2 + \frac{1}{R_2}\right)} = -\frac{\Delta P_{L1}}{\beta_1 + \beta_2} \quad \text{and} \tag{11}$$

$$-\frac{\Delta P_{L1} \left(D_2 + \frac{1}{R_2}\right)}{\left(D_1 + \frac{1}{R_1}\right) + \left(D_2 + \frac{1}{R_2}\right)} = -\frac{\Delta P_{L1} \beta_2}{\beta_1 + \beta_2} \tag{12}$$

Where  $\beta_1$  and  $\beta_2$  are the composite frequency response characteristics of areas 1 and 2 respectively. The above relationships are depicted in Figure 4 [2].

Figure 4 effect of change in area 1 load

An increase

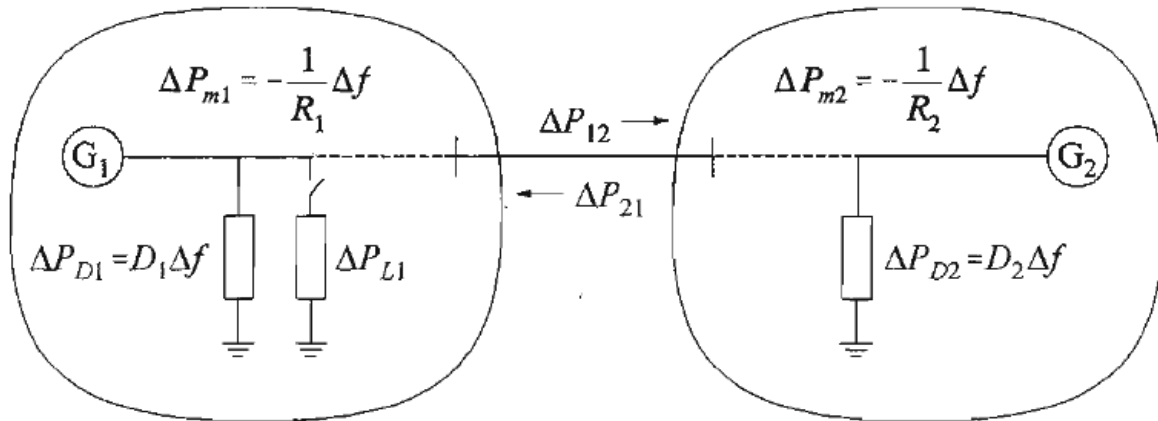

Figure 5 Effect of change in area 1 load

An increase in area 1 load by  $\Delta P_{L1}$  results in a frequency reduction in both areas and a tie line flow of negative  $\Delta P_{12}$  is indicative of flow from area 2 to area 1. The tie line flow deviation reflects the contribution of the regulation characteristics ( $1/R + D$ ) of one area to another.

Similarly, for a change in area 2 load by  $\Delta P_{L2}$  we have

$$\Delta f = \frac{\Delta P_{L2}}{\beta_1 + \beta_2} \quad \text{and} \tag{13}$$

$$\Delta P_{12} = -\Delta P_{21} = \Delta P_{L2} \frac{\beta_1}{\beta_1 + \beta_2} \tag{14}$$

The above relationships form the basis for the load frequency control of interconnected system.

## 2.2 AGC system considering Governor Dead-band

The effect of the governor dead-band is that for a given position of the governor control valves, an increase/decrease in speed can occur before the position of the valve changes. In governor operation, mechanical friction and backlash and also valve overlaps cause the governor dead-band. Due to this, though the input signal increase/decrease, the governor may not immediately react until the input reaches a particular value. Thus the governor dead-band is defined as total magnitude of sustained speed change within which there is no change in valve position. The limiting value of dead-band is specified as 0.06%. An effect of the governor dead-band on AGC operation is to increase the apparent steady state frequency regulation.

In the presence of GRC and dead-band even for small load perturbation. The system becomes highly non-linear and hence the optimization problem becomes rather complex.

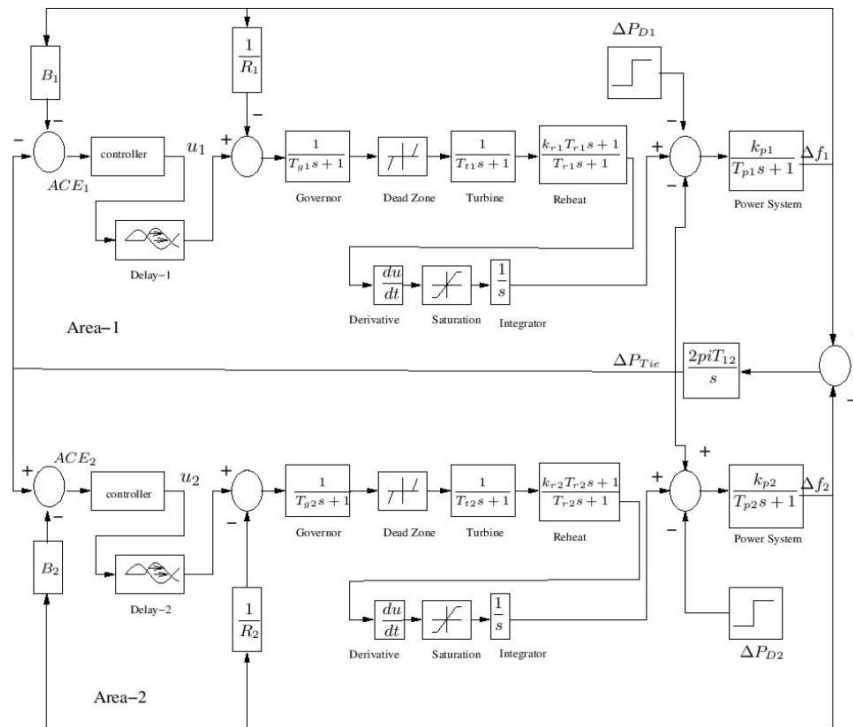

Figure 6 Two area power system considering generation rate constraint and governor dead-band [4] [15]

### 3 Results and Discussions

Consider a two are system having the following specification

$P_r$  = rated capacity = 2000MW

$K_{psi}$  = power system gain for  $i^{th}$  area = 120HZ/ MW

$T_{psi}$  = power system time constant for  $i^{th}$  area = 20 sec

$T_{sgi}$  = governor time constant = .4 sec

$T_{ti}$  = turbine time constant = .2sec

$T_{12}$  = Tie line time constant = 0.01sec

$B_i$  =frequency bias for  $i^{th}$  area = 0.405

$R_i$  = speed droop for  $i^{th}$  area = 1.65

The PI controller exhibits frequency deviations of  $51 \times 10^{-3}$  Hz and  $52 \times 10^{-3}$  for areas 1 and 2, respectively presented in Table 1. It also has a tie line power deviation of  $11 \times 10^{-5}$  pu, a settling time of 44 seconds, and an overshoot of 0.050 pu. These results indicate that the PI controller, while functional, shows relatively high frequency deviations, longer settling times, and higher overshoot, highlighting its limitations in dynamic response and stability.

**Table 1 Comparison of results for PI, PID, Fuzzy PI and ANFIS controller**

Controller	$f_1$	$f_2$	Tie line power	Settling time	Overshoot
<b>PI</b>	$51 \times 10^{-3}$	$52 \times 10^{-3}$	$11 \times 10^{-5}$	44 sec	0.050pu
<b>PID</b>	$42 \times 10^{-3}$	$44 \times 10^{-3}$	$15 \times 10^{-6}$	27sec	0.043pu
<b>Fuzzy PI</b>	$24 \times 10^{-3}$	$28 \times 10^{-3}$	$16 \times 10^{-6}$	25 sec	0.027pu
<b>ANFIS</b>	$9 \times 10^{-2}$	$11 \times 10^{-2}$	$23 \times 10^{-4}$	10 sec	0.020pu

The PID controller shows improvement over the PI controller, with lower frequency deviations of  $42 \times 10^{-3}$  Hz and  $44 \times 10^{-3}$  Hz, a tie line power deviation of  $15 \times 10^{-6}$  pu, a reduced settling time of 27 seconds, and an overshoot of 0.043 pu. This indicates a better performance in terms of stability and response time.

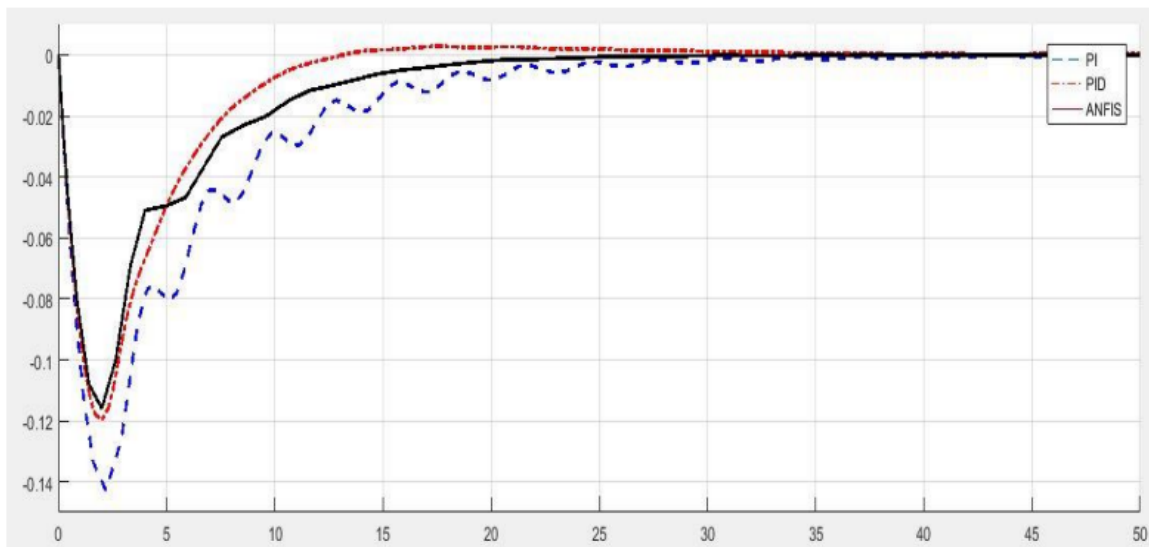

Figure 7 Frequency deviation of area 1

Further enhancements are observed with the Fuzzy PI controller, which significantly lowers frequency deviations to  $24 \times 10^{-3}$  Hz and  $28 \times 10^{-3}$  Hz. It also reduces the tie line power deviation to  $16 \times 10^{-6}$  pu, achieves a faster settling time of 25 seconds, and minimizes the overshoot to 0.027 pu. These improvements demonstrate the Fuzzy PI controller's superior capability to handle non-linearity's and dynamic changes more effectively than conventional controllers.



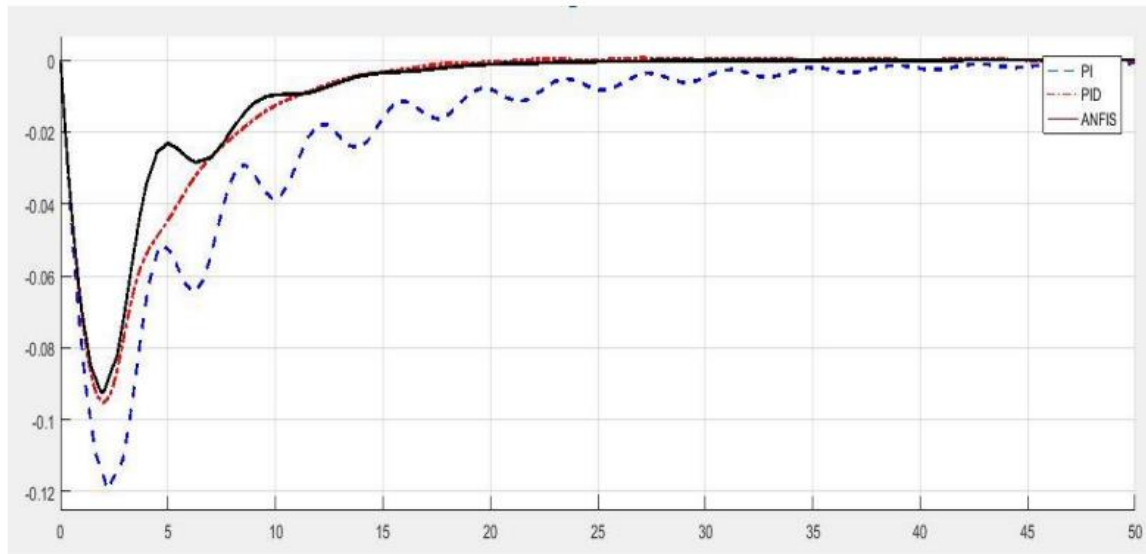

Figure 8 Frequency deviation of area 2

The ANFIS-based Neuro-Fuzzy controller surpasses all other controllers, demonstrating exceptional performance with the lowest frequency deviations of  $9 \times 10^{-3}$  Hz and  $11 \times 10^{-3}$  Hz indicated in Figure 7 and 8. It manages tie line power deviation at  $23 \times 10^{-4}$  pu, achieves the shortest settling time of 10 seconds, and minimizes the overshoot to 0.020 pu. This indicates the ANFIS controller's superior adaptability and efficiency, making it the most effective solution for maintaining load frequency control in interconnected power systems.

Each successive controller shows improvements over its predecessor, the ANFIS-based Neuro-Fuzzy controller stands out as the optimal choice for ensuring system stability and quick response in load frequency management.

#### 4 Conclusion

In power systems, maintaining a steady frequency at its nominal value is crucial for reliable grid operation. Load changes cause frequency deviations, necessitating quick controller actions to restore the frequency to its nominal value within seconds. Various controller strategies have been employed to adjust parameters and ensure the frequency remains stable at 50Hz in the shortest possible time. The performance of the neuro-fuzzy controller has been compared with other conventional controllers, demonstrating that the neuro-fuzzy controller is highly effective for controlling non-linear processes. In a two-area control system, non-linear processes play a significant role, and a controller capable of managing these complexities is essential. The neuro-fuzzy controller meets these requirements, making it a suitable choice for comprehensive system control.

The results obtained using the ANFIS-based neuro-fuzzy controller in this study demonstrate substantial improvements over conventional PI and Fuzzy Logic controllers. Thanks to its hybrid learning algorithm, it effectively controls frequency deviations in a three-area system, enhancing dynamic performance. Specifically, the neuro-fuzzy controller achieves frequency deviations of  $9 \times 10^{-3}$  Hz and  $11 \times 10^{-3}$  Hz, a tie line power deviation of  $23 \times 10^{-4}$  pu, a settling time of 10 seconds, and an overshoot of 0.020 pu. These results show significant improvements compared to the PI and Fuzzy Logic controllers, confirming the ANFIS-based neuro-fuzzy controller's superior adaptability and efficiency. The designed Simulink models have been

tested and verified within MATLAB/SIMULINK, showing reduced fluctuations in the network and underscoring the controller's efficacy.

### References

- [1] S. Ajithapriyadarsini, P. M. Mary, and M. W. Iruthayarajan, "Automatic generation control of a multi-area power system with renewable energy source under deregulated environment: adaptive fuzzy logic-based differential evolution (DE) algorithm," *Soft comput*, vol. 23, no. 22, pp. 12087–12101, Nov. 2019, doi: 10.1007/s00500-019-03765-2.
- [2] I. Vijay Kumar Singh Department of Electrical Engineering National Institute of Technology Kurukshetra Kurukshetra and I. RatnaDahiya Department of Electrical Engineering National Institute of Technology Kurukshetra Kurukshetra, *Automatic Generation Control System Using PI and FIS Controller*. 2018.
- [3] Satish kumar Mitta and Prof. Anil Kumar Sharma, "AGC Issues in Power System Operation After Deregulation using PI and PID Controller," 2017.
- [4] B. O. I. Deepak Kumar Lal Department of Electrical Engineering Veer Surendra Sai University of Technology, B. O. I. Ajit Barisal Department of Electrical Engineering College of Engineering and Technology, and B. O. I. Ajit Barisal Department of Electrical Engineering College of Engineering and Technology, *AGC of a two area nonlinear power system using BOA optimized FOPID+PI multistage controller*. IEEE, 2019.
- [5] M. K. Das, P. Bera, and P. P. Sarkar, "Discrete Mode AGC of Restructured Power System using P-I Controller with Governor Dead-band Nonlinearity."
- [6] Dayananda Sagar Academy of Technology & Management, Institute of Electrical and Electronics Engineers. Bangalore Section., and Institute of Electrical and Electronics Engineers, "AGC and AVR implementation in a deregulated power system using optimized controller with Renewable integrated DC link," 2019.
- [7] E. Çelik and N. Öztürk, "Novel fuzzy 1PD-TI controller for AGC of interconnected electric power systems with renewable power generation and energy storage devices," *Engineering Science and Technology, an International Journal*, vol. 35, Nov. 2022, doi: 10.1016/j.jestch.2022.101166.
- [8] A. Ghasemi-Marzbali, "Multi-area multi-source automatic generation control in deregulated power system," *Energy*, vol. 201, Jun. 2020, doi: 10.1016/j.energy.2020.117667.
- [9] P. Dash, L. C. Saikia, and N. Sinha, "Automatic generation control of multi area thermal system using Bat algorithm optimized PD-PID cascade controller," *International Journal of Electrical Power and Energy Systems*, vol. 68, pp. 364–372, 2015, doi: 10.1016/j.ijepes.2014.12.063.
- [10] Y. Arya, "A new optimized fuzzy FOPI-FOPD controller for automatic generation control of electric power systems," *J Franklin Inst*, vol. 356, no. 11, pp. 5611–5629, Jul. 2019, doi: 10.1016/j.jfranklin.2019.02.034.
- [11] T. Mohammed, J. Momoh, and A. Shukla, "Single Area Load Frequency Control using Fuzzy-Tuned PI Controller."

- [12] R. I. Durga Kalyan, Gp. Kumar, C. Durga Prasad, and P. scholar, "Effect of Load Variations on AGC of an Interconnected Hydro-Thermal Power System in Presence of Conventional PI and FL Controllers."
- [13] Yu Weng, Yu Weng, and N. S. EEE, *A New Generation of AGC using Repetitive Learning*. 2020.
- [14] G. M. Meseret and L. C. Saikia, "A Comparative Performance Analysis evaluation of Automatic Generation Control (AGC) of Multi-Area Power System with the impact of HVDC Links on the System Frequency using the Conventional PID and Adaptive Neuro-Fuzzy Controller," in *IFAC-PapersOnLine*, Elsevier B.V., 2022, pp. 138–143. doi: 10.1016/j.ifacol.2022.04.023.
- [15] M. Raju, L. C. Saikia, and N. Sinha, "Automatic generation control of a multi-area system using ant lion optimizer algorithm based PID plus second order derivative controller," *International Journal of Electrical Power and Energy Systems*, vol. 80, pp. 52–63, Sep. 2016, doi: 10.1016/j.ijepes.2016.01.037.

## Nomenclature

	ACRONYMS		ABBREVIATION
ANFIS	Adaptive Neuro Fuzzy Interface System	$P_{12}$	Power on Tie line
PI	Proportional Integral	$P_L$	Total Load
PID	Proportional Integral derivative	$f_1$	Frequency Deviation of area 1
FL	Fuzzy Logic	$f_2$	Frequency Deviation of area 2
AGC	Automatic Generation Control	$P_r$	rated capacity
LFC	Load Frequency Control	$K_{psi}$	Power system gain for $i^{\text{th}}$ area
GENCos	Generation Corporation	$T_{psi}$	Power system time constant for $i^{\text{th}}$ area
ISOs	Independent System Operator	$T_{sgi}$	Governor time constant
TRANS Cos	Transmission Corporation	$T_{ti}$	Turbine time constant
PS	Power System	$T_{12}$	Tie line time constant
		$B_i$	Frequency bias for $i^{\text{th}}$ area
		$R_i$	Speed droop for $i^{\text{th}}$ area