



African Journal of Biological Sciences



Design and Performance Test of an Implementable Rectenna Encapsulated in a Human Tissue Bio-Case Model

Sadman Shahriar Alam^{1*}, MD. Ashiquzzaman², Protik Parvez Sheikh³, Shuvra Mondal², Abu Shufian¹, S M Tanvir Hassan Shovon¹

¹Lecturer, Department of Electrical and Electronic Engineering, Faculty of Engineering, American International University Bangladesh (AIUB), Dhaka, Bangladesh.

²Assistant Professor, Department of Electrical and Electronic Engineering, Faculty of Engineering, American International University -Bangladesh (AIUB), Dhaka, Bangladesh.

³Senior Lecturer, Department of Electrical and Electronic Engineering, Faculty of Engineering, American International University -Bangladesh (AIUB), Dhaka, Bangladesh.

Corresponding author

*Sadman Shahriar Alam, Lecturer, Department of Electrical and Electronic Engineering, Faculty of Engineering, American International University -Bangladesh (AIUB), Dhaka, Bangladesh. Email: sadman.alam@aiub.edu

ABSTRACT

Article History
Volume 6, Issue 13, 2024
Received: 18 June 2024
Accepted: 02 July 2024
Published: 30 July 2024

Modern implanted medical devices perform a range of diagnostic and therapeutic activities such as sensing, monitoring, and medication administration. Although these medical devices can communicate with the outside world, they face a number of difficulties including inefficient power supplies, size reduction, and short working lifespans. An implantable antenna designed with a rectifier circuit has been proposed in this research paper. Moreover, the rectifier circuit's (Rectenna) performance has been evaluated by its efficiency and the output voltage at the receiver's end. This report depicts a thorough process of the design and simulation results for both antenna and a rectifier circuit. The patch antenna was created to function at the Industrial, Scientific, and Medical (ISM) band within the frequency range of (902-928) MHz which is encapsulated between the skin and muscle layer to create a practical simulation environment. To transfer the maximum power, a matching network circuit has been designed. To convert RF voltage to DC voltage, a double-stage voltage rectifier circuit was used.

Keywords: antenna, rectifier, rectenna, ISM band, bio-case model, RF-DC conversion, skin & muscle tissue, wireless power transfer.

INTRODUCTION

Scientists and engineers are currently focusing on developing novel strategies and cutting-edge technologies that can improve the effectiveness of power to compensate for the gradual depletion of traditional energy sources. RF-based wireless power transfer (WPT), a promising technology that is being scrutinized, has the potential to entirely alter how we charge our electronic devices. There are several applications or areas where WPT technology can be used [1], [2]. It enables wireless sensing, communication, and powering, allowing for seamless and convenient wireless applications. One of the major fields of WPT, where much research is currently happening, is biomedical implants. While wireless sensing and

communication have been well-established, wireless power transfer is still in its developmental stage. However, WPT has a range of potential

uses in various applications including mobile phone charging, RFID tags [3], and even biomedical implants. Wireless power distribution enables radio wave communication [4] to run efficiently and safely while removing the need for wires, reducing the risk of infection; yet, depending on usage, packed batteries are able to power the implants for only a brief amount of time [3]– [7]. So, the goal is to develop an effective model for RF- DC conversion for the implants via wireless power transfer system. The scientific community has recognized the importance of radio frequency-based wireless power transfer, particularly for sensor networks that are a component of the Internet of Things (IoT) [8]. Efficient model designs for RF-DC conversion in wireless power transfer are critical for maximizing the system's energy conversion efficiency (ECE). The electromagnetic meta surface, which operates at 10 GHz and can effectively reflect an incoming incident wave at different reflection angles, is discussed in this research [9]. The design of a PIFA antenna for biomedical applications at the ISM band (2.45 GHz) is discussed in [10]. Authors demonstrated antenna optimization inside the simulated human tissue model and evaluated the results in skin tissue gel [10]. For patients with implanted medical devices, this technology has the potential to improve their quality of life greatly [11].

Wireless power transfer (WPT) has become an increasingly important technology for the development of implantable medical devices, such as pacemakers, neuro-stimulators, and drug delivery systems. Realizing effective and dependable power transmission over a distance without sacrificing patient safety is one of the significant problems facing implanted WPT devices. This has led to the development of implantable rectennas, which are devices that can convert electromagnetic waves into DC power for implantable devices. The design of an implantable rectenna involves various factors such as antenna size, frequency range, efficiency, and implant compatibility. This paper will provide an overview of the design considerations and challenges for developing an implantable rectenna for WPT applications, as well as recent advances and future directions in this field. The design of an implanted rectenna includes both an antenna for receiving electromagnetic waves and a rectifier for converting the sinusoidal signal into DC electricity. The antenna should be optimized for the specific frequency range of the WPT system and have a small size to fit within the limited space of the implantable device. The rectifier should have high conversion efficiency to maximize power output while minimizing energy loss. Furthermore, implantable rectennas must be designed to be biocompatible and safe for long-term implantation in the human body. The materials used in the rectenna should be non-toxic and non-allergenic, and the device should not generate excessive heat or electromagnetic interference that could harm the patient [1], [2], [12]– [14].

Recent advances in materials and fabrication techniques, such as nanotechnology and 3D printing, have enabled the development of more compact and efficient implantable rectennas. These technologies offer the potential for further miniaturization and improved performance of the rectennas, thereby increasing their applicability in various implantable medical devices. The design of an implantable rectenna for WPT applications is a complex process that involves multiple factors, including antenna size, frequency range, efficiency, and biocompatibility. The development of more advanced materials and fabrication techniques is expected to further enhance the performance and applicability of implantable rectennas, laying the foundation for the next generation of implantable medical devices.

The ability of implanted medical devices (IMDs) to be accessed remotely has been a significant focus of biomedical engineering [11], [13]. With remote patient state monitoring, wireless RFID tags [4], [11] can foster an enhanced quality of life and lessen worries about an urgent medical condition. Due to the implantable devices' prolonged use, the power supply issue also emerges. The typical feeding mechanisms are electrical power systems and electrochemical energy sources (like batteries). The former's size and functionality rely on the battery's capacity and longevity, whereas the latter might infect and irritate the patient. Wireless power transfer (WPT) might remove the need for recurring operations and other medical problems [13], [14].

LITERATURE REVIEW

Inter-modulation is a novel WPT antenna alignment technique discussed in [1] and allows for accurate antenna misalignment control. Rectification is facilitated and inter-modulation is induced via the use of a Two-tone waveform excitation. The inter-modulation's power is returned through a magnetic resonant coupling link. The receiving antenna on

the body must be lined up with the sending antenna (outside the body) due to the monotonic connection between the inter-modulation power and the level of antenna misalignment. By using this method, the disturbance of the relationship between the two-tone waveform excitation and the magnetic resonance coupling causes less harm to human tissue. The system has undergone theoretical analysis, and experimental evidence has been provided to support its validity.

The ISM band of 2.4-2.48 GHz is used to evaluate microwave wireless power transfer. An implanted antenna with circular polarization and an in-built voltage-doubled rectifier are used [2]. The projected antenna's size was decreased by cutting four slots in the patch in the shape of a C. The antenna's circular polarization performance is improved by a rectangular slot with a diagonal truncation. In order to convert RF power into DC power, a voltage-doubled rectification circuit is built into the antenna's back end. The maximum simulated efficiency for RF-to-DC conversion at 0 dBm input power can be as high as 45%. The suggested rectenna was implemented in a novel pork environment to confirm the anticipated results and assess the practicality of wireless power transfer.

Literature [12] suggests a unique rectenna for wireless data telemetry and power transfer that is implanted in the arm. It is supported by a PIFA (Planar Inverted F-Antenna) and rectifier, and it can operate in the ISM (902.8-928 MHz) and Medical Device Radiocommunications Service (401-406 MHz) bands. The ground plane of the antenna is used to integrate a rectifier circuit into the system, allowing for consistent power delivery to the implanted devices. Each stage of development is followed by theoretical analysis and then experimental validation. The radiation and safety characteristics, as well as the resonance stability, of a PIFA are demonstrated. In addition, a matching layer (ML) is proposed to be added to the arm to improve wireless power transmission efficiency. Next, the rectifier circuit is analyzed so that the highest possible conversion efficiency can be achieved even with minimal input power. The final rectenna was created via a meticulous design procedure, and measurements verified its overall effectiveness.

A rectenna converts electromagnetic waves into electrical power in the implanted wireless transmission system for biomedical purposes described in the literature [14]. To implant in living tissue, the compact, energy-efficient system was encased in biocompatible material. The system powered and communicated with many biomedical sensors after extensive testing. This technology could be used for neural stimulation, drug delivery, and vitals monitoring. An alternative proposal for a dual frequency rectenna, usable in the 0.915 GHz and 2.45 GHz bands is provided in another paper [13], which is intended for use in biomedical implantable devices. The rectenna comprises an efficient dual-band rectifier circuit and a capsule device that houses a tiny dual-band antenna based on a resonator. Making and installing an implantable antenna and rectifier within a capsule device constitutes an experimental validation of the rectenna. The suggested rectenna can implant dual-band RF signal rectification into a single load, making it superior to single-band rectennas.

METHODOLOGY

A. Modelling of the Antenna

Wireless medical devices, biosensors, and other implantable medical electronics can use a rectangular patch antenna that operates in the ISM band.

i) Allocation of Frequencies: The ISM band operates in the range of frequencies between 2.4 and 2.4835 GHz, or 902 and 928 MHz in North America and Europe, respectively. The requirements of the medical application should be used to choose the patch antenna's ideal frequency. Developing an antenna for a low-power, short-range wireless system that can be used with an implantable medical device is the aim of this effort. The proposed antenna will resonate at the 915 MHz frequency, which lies in the middle of the (902-928) MHz band.

ii) Phantom model design: The design of a body phantom is crucial for mimicking an antenna's performance in a real-world environment, which is based on the mode of operation of the antenna. In other words, the antenna should yield a similar outcome when applied to a human. To mimic human tissue, a phantom layer was created. The phantom is a tissue layer that includes skin, muscle, and bone. In this study, we modeled the muscle and skin of the human arm as a two-layer structure. We employed a cube of two different tissues with a cross-sectional area of 3 cm by 3 cm and frequency-dependent features as the phantom. The phantom's layer, shown in Fig. 1 (b), comprised 2.5mm of skin and 10mm of muscle over the x-y plane. This design, which comprises simply two straightforward geometrical layers, was inspired by the human arm. Because lossy materials are comparable to the actual tissues being simulated and yield results that are reasonably close to those produced in practice, they were chosen for the phantom layer.

The dielectric permittivity ϵ_r and conductivity σ values of human tissues such as skin and muscle tissue are shown in Table 1. Table 1 provides a list of the dielectric characteristics of several human tissues, including skin and muscular tissue. To get the best results, it's crucial to keep these numbers constant based on the operating frequency.

Table 1: Electric properties of the tissue

Tissue	915 M	
	ϵ_r	
Skin	41.33	
Muscle	54.99	

Table 2: Dimensions of the antenna layer

Measurements	Value
Length(mm) of the substrate and superstrate	10
Thickness (mm) of substrate and superstrate	0.635*2
Standards cooper cladding (m)	18

iii) Design a bio-case: Biocompatibility must be a key priority when designing an implanted device. Antennas can be made physiologically compatible in one of two ways: by utilizing biocompatibility materials in the substrate and superstrate, or by using a biocompatibility case with no biocompatibility materials. This work will explore the second technique during the antenna design phase. Silastic MDX4-4210 ($r = 3$, $\tan(\delta) = 0.001$) was used to make the biocompatible casing 0.2 mm thick. The antenna design's substrate will be Rogers RO6010 ($r = 10.2$ and $\tan(\delta) = 0.0023$).

iv) Antenna design: The operating frequency and installation region will determine the patch antenna's dimensions and design. A rectangular patch antenna is a feasible solution for implantable applications because of its minimal complexity and straight forward fabrication procedure. The patch must be large enough to deliver the necessary radiation pattern while still being small enough to be surgically placed. Figure 1. (a) depicts the antenna model in free space, which includes the antenna's top and bottom layers. This antenna's final dimensions are $10 \times 10 \text{ mm}^2$. CST Microwave Studio is used for all simulations. A three-layer human phantom model shown in figure 1. (b) is implanted with the designed antenna after free space calculations. Copper (Cu) has been utilized in the construction of both grounds. The layer's thickness is not specified. The patch antenna's substrate and superstrate should be biocompatible and non-toxic. Polyimide, Parylene C, and liquid crystal polymer (LCP) are popular materials for implantable antennas. Rogers RO6010 will be used as the substrate and superstrate for the antenna design ($\epsilon_r = 10.2$ and $\tan(\delta) = 0.0023$). This project's objective is to design a miniature antenna with a thickness of 0.635 mm and 18 m of copper cladding as shown in table II. The 1 cm square planar surface was designed with a substrate and superstrate height of 0.635 mm.

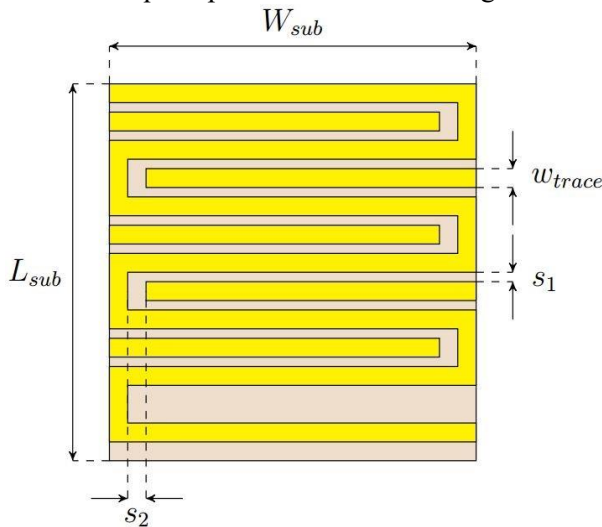

(a) Patch with all the dimensional parameters of the antenna

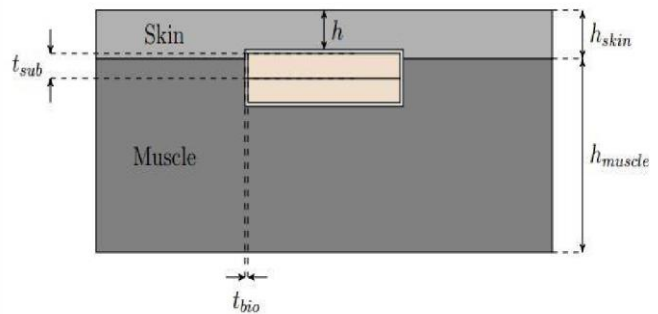

(b) Antenna inside the two-layer geometry model

Figure 1. The final optimized antenna's measurements B.

Modelling of the Antenna

The system's primary components are RF waves, the impedance matching network, and the rectifying circuit. The block diagram in figure 2. (a) shows an example of a common RF energy harvesting system.

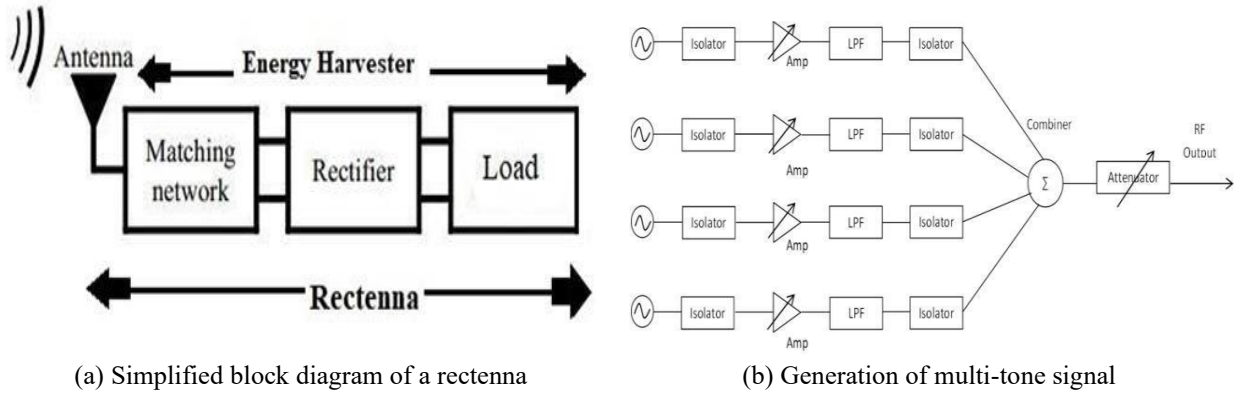

Figure 2. Rectenna design along with RF signal generation

A combiner adds all output signals to produce an RF signal. It is evident from figure 2. (b) that four distinct signal generators are combined to produce a four-tone signal. For frequency domain analysis of nonlinear circuits, the simulation was conducted using the ADS (Advanced Design Simulation) software and a harmonic balance (HB) simulator. In the 2stage RF-DC rectifier circuit, a nonlinear diode model SMS285B was used, followed by a parallel-connected shunt capacitor CL and a resistive load RL. As RF inputs for the experiment, a variable power source with a single tone and a dual-tone source were used, and the HB simulator was used to calculate the currents and voltages at a number of harmonically related frequencies. By varying the input power with the HB simulator, optimum parameter values or performance trends could be observed.

The input impedance of the rectifier needs to match the output impedance of the RF receiving antenna for optimum power transmission from source to load. The simulation circuit has a source impedance of $Z_S = 50 + j0$ ohm and a load impedance of $Z_L = 100 j*0.176$ ohm. By generating the necessary lumped components to connect two points on the chart representing source and load impedance, the Smith chart matching palette can be used to accomplish a matching network. Figure 3 (a) depicts the Smith chart, as well as the T-shaped impedance matching network in figure 3 (b) that was generated using the chart.

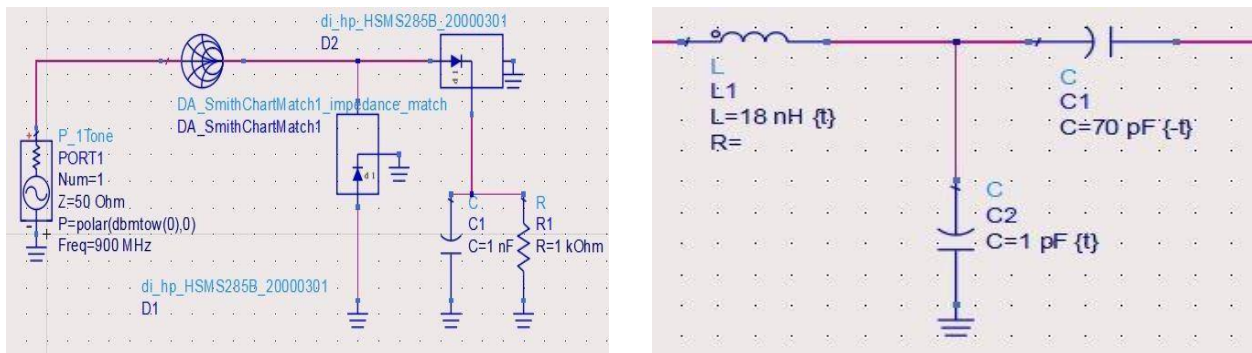

Figure 3. Rectenna design along with RF signal generation

Because it rectifies the full-wave peak-to-peak voltage of the incoming RF signal, the double-stage voltage rectifier circuit is used in the development of the RF-DC power conversion system. The doubler circuit is comprised of two diodes, D_1 and D_2 . During the positive half cycle, the capacitor is charged as D_1 conducts. While the negative half-cycle D_2 conducts, the capacitor is once again charged. Therefore, the output voltage,

$$V_{out} = 2V_{RFpeak} - D_1 - D_2$$

Literature [6] demonstrates that increasing the number of stages can enhance the output DC voltage. Referring to the research [6], it is clear that the additional rectification stages have improved the RF-DC conversion efficiency, and for greater RF input power, the DC voltage rises more quickly. Following the development of the rectifier and impedance matching network, the main circuit was completed using the measured ideal values for the capacitor and inductor. Figure 4 shows the completed circuit model. The four main components of the circuit are the power source, impedance matching network, rectifier circuit, and load. A single-tone power source and the HB simulator are shown in figure 5. (a). The HB simulator's $Freq [1] = 915MHz$ was chosen as fundamental frequency. The number of harmonic frequencies to be determined for the single tone frequency is shown by the $order [1] = 3$. It is possible to use the HB simulator to sweep the input power to find the ideal parameter values or spot performance trends because the input power P_{in} of the RF signal is a variable represented by a 'VAR', in figure 5(a). A dual tone as RF input and associated HB simulator configuration has been shown in figure 5. (b). The 915 MHz and 915.1 MHz are the two frequencies that are used for the RF signal. Each one was given a power input of 2dBm.

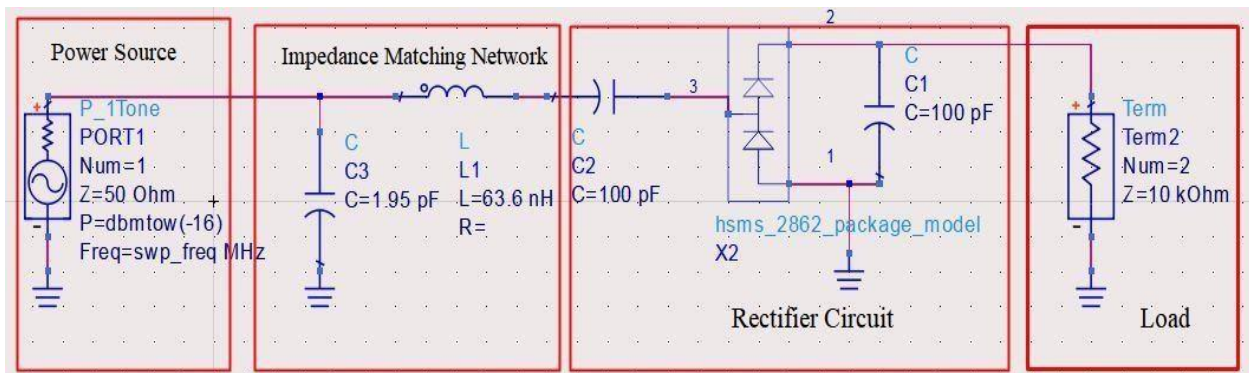
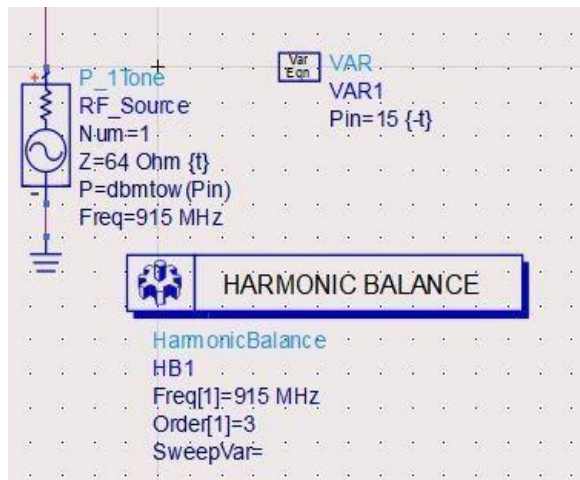
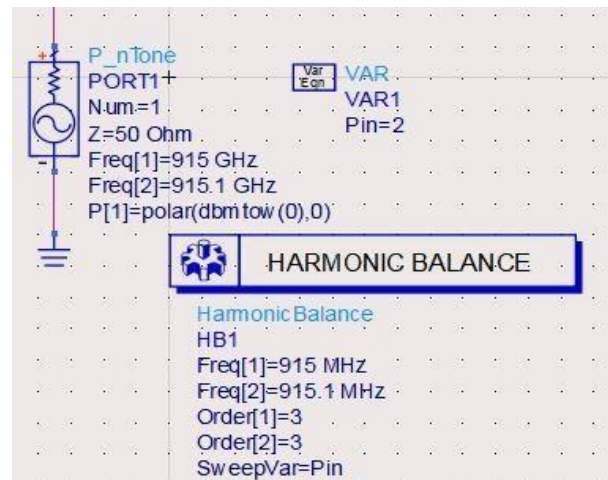

Figure 4. Final circuit model for the rectenna



(a) HB simulator setup for single tone



(b) HB simulator setup for dual tone

Figure 5. Final circuit model for the rectenna

RESULT AND DISCUSSION

A. Antenna

i) **Antenna's Dimension:** After optimization, the final dimension of the antenna is measured to be 10mm x 10mm x 1.27mm. The complete set of dimensional parameters for the antenna and the antenna within the two-layer tissue model are shown in Fig. 1 (a) and (b), respectively. The precise values of the optimized size parameters are shown in table 3. From the parameters seen from table 3, it can be observed that the antenna size is reduced by approximately 50% comparing with the other antennas given in table 4. The volume of each antenna from the references are measured to be 3072mm^3 , 857.25mm^3 , 530.4mm^3 , 691.52mm^3 and 675mm^3 respectively. For the proposed antenna the volume is measured to be 172mm^3 , which is much less than the other antennas discussed in the reference literature.

ii) **Antenna's Performance:** The antenna was encapsulated inside the human tissue model once it had been optimized. The performance of the antenna was evaluated by measuring the return loss which is also called the reflected power from the antenna. The return loss is lowest at 915 MHz, with a value of 14.814 dB, meaning the reflected signal has significantly less loss than the emitted signal. This is seen in figure 6.

Table 3: Antenna size parameters

Parameter	Size,
W	10.1
L_{sub}	10.1
w_{trace}	0.5
s_1	0.2
sw	0.5
t_{sub}	1.2
h_{muscle}	10.
h_{skin}	2.5
t_{bio}	0.2
h	2.0

Table 4: Dimension comparison of various antenna

Ref	Type	Dimensions, mm	Miniaturization Method
[15]	PIFA	32x24x4	PIFA
[16]	Patch	15x15x3.81	Split ring resonator
[17]	PIFA	8x13.1x5.1	Multi-layer PIFA
[18]	PIFA	16.5x16.5x2.54	Spiral PIFA
[19]	Dipole	10x10x0.675	Inductive loading
Proposed	Patch	10x10x1.27	Lengthening current path

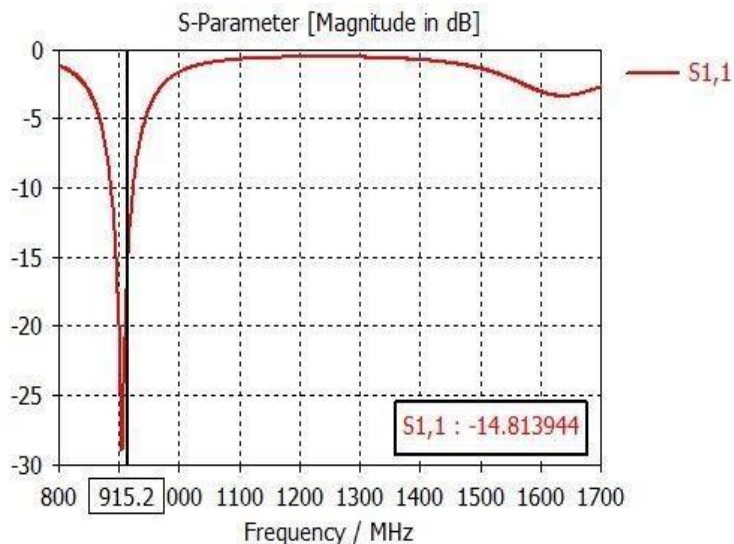

Figure 6. Reflection coefficient of the antenna at 915 MHz frequency

B. Rectifier Circuit

i) RF to DC conversion: Figure 7 (a) uses the waveform of a single-tone RF signal as input. In this case, the output voltage is $V_{out} = 1.610$ V, and the peak voltage is $V_{RFpeak} = 1.430$ V. The output voltage ought to have been 0.102V, based on the voltage doubling theory. But we were able to achieve a better result. A dual tone RF to DC rectification with frequencies of ($f_1 = 915$ MHz and $f_2 = 915.1$ MHz) is shown in figure 7 (b). The RF peak voltage is $V_{RFpeak} = 0.802$ V, while the DC output voltage is $V_{out} = 0.915$ V. In theory, the output voltage ought to have been 1.6V. The voltage drops in the two diodes, however, caused the output to fall short of the desired result. It's crucial to remember that the input power for the dual tone was meant to be -8 dBm, and for the single tone, -16 dBm. In order to equalize the power levels for the two tones, the dual tone was given half the input power (-16 dBm) of the single tone. Table 5 indicates that while both tones are given the same power level, the single tone has a greater input and output voltage level.

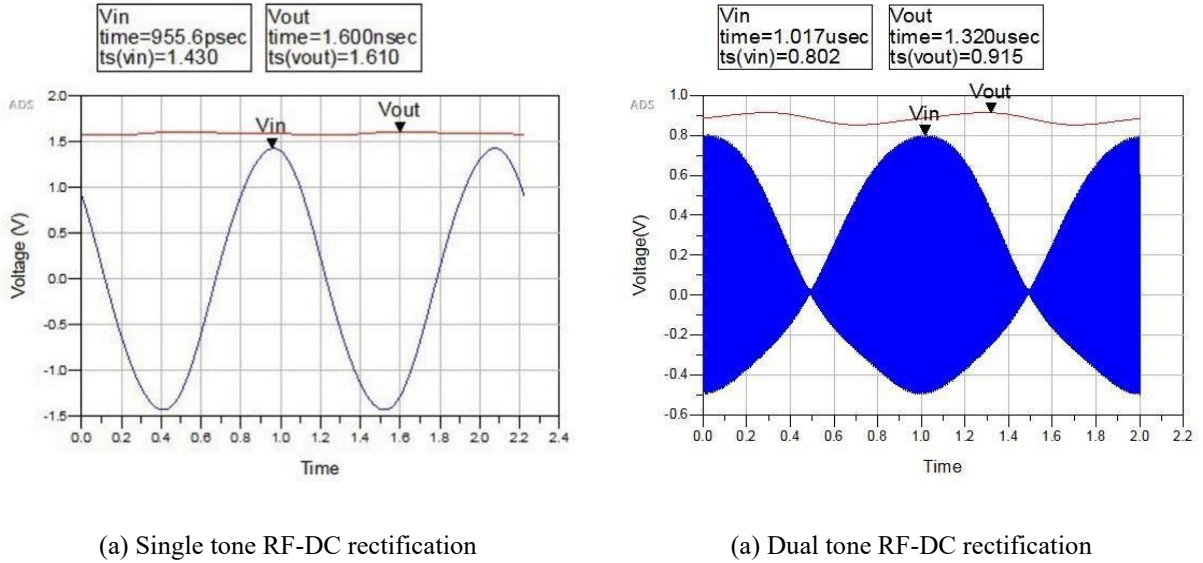

Figure 7. Double stage RF-DC conversion

Table 5: Comparison of acquired RF-DC voltage single and dual-tone source

Source	Single Tone	Dual Tone
Input Power (dBm)	-16	-8 (each tone)
Input Voltage (V)	0.051	0.802
Output Voltage (V)	0.314	0.915

ii) Efficiency Measurement: The RF to DC conversion efficiency is regarded to be the primary performance indicator of a rectifier circuit. Using the following equations, efficiency can be calculated.

$$\eta = (P_{DC} / P_R) * 100\% \quad \eta = [(V_{DC})^2 / R_L * P_R] * 100\%$$

Here, P_{DC} = Output DC power,
 P_R = Received power by the implanted antenna,
 V_{DC} = DC output voltage, R_L = Load resistance.

The RF to DC conversion efficiency was measured by writing equations in the ADS simulation and the received power by the implanted antenna was considered to be -16 dBm as we considered this value to be the reference power level. The

received power is converted to Watt from dB value which is found out to be 25.1186 micro-Watt and thus used in the equation. For sweeping the load value, Z_{Load} was measured by dividing voltage output with input current.

The RF to DC conversion efficiency is simulated. The result was observed from the equation generated in ADS software and the conversion efficiency is measured to be 39.39% and output DC voltage is achieved to be 0.31V at -16 dBm input power for an optimum load of 10K

CONCLUSION

The article outlines a modeling and design strategy for an implanted rectenna intended for wireless power transfer from medical devices. The patch antenna was optimized using CST Microwave Studio software for the ISM band (902-928 MHz). Using ADS software, a matched network circuit was built to transfer the most amount of energy. The antenna is concealed in the bio-case between the layer of muscle and skin to replicate reality. The paper covers the design and development of an ISM band patch antenna as well as a rectifier circuit. The size, frequency range, and efficiency of the antenna were optimized for ISM band operation based on the simulation findings. Based on the aforementioned calculations, the rectenna's RF-to-DC conversion has an operational effectiveness of 39.39%.

REFERENCES

- [1] H. Zhang, S.-P. Gao, T. Ngo, W. Wu, and Y.-X. Guo, "Wireless power transfer antenna alignment using intermodulation for two-tone powered implantable medical devices," *IEEE Trans. Microwave Theory Techniques*, vol. 67, no. 5, pp. 1708–1716, 2019.
- [2] C. Xu, Y. Fan, and X. Liu, "A circularly polarized implantable rectenna for microwave wireless power transfer," *Micromachines*, vol. 13, no. 1, p. 121, 2022.
- [3] M. A. A. R. Rakib, M. S. R. Zishan, and M. A. H. Abid, "Energy harvesting technology by converting waste heat energy from automobiles," *AIUB Journal of Science and Engineering (AJSE)*, vol. 20, no. 4, pp.127–132, 2021.
- [4] D. Chakraborty, M. M. Rahman, Z. H. Joy, M. A. Islam, A. Shufian, P. P. Sheikh, and S. S. Alam. "Enhanced Security and Efficiency in Attendance Management: A Novel RFID and Arduino Integrated System". *Journal of Engineering Research and Reports*, vol. 26, no. 5, Apr. 2024, pp. 59-65, doi:10.9734/jerr/2024/v26i51134.
- [5] P. P. Sheikh, T. Riyad, B. D. Tushar, S. S. Alam, A. Shufian, and I. M. Ruddra, "Thyristor-based Rechargeable Battery Charger", *J. Eng. Res. Rep.*, vol. 26, no. 3, pp. 104–112, Feb. 2024.
- [6] S. S. Alam, A. J. Islam, M. M. Hasan, and F. K. Nadim, "Energy harvesting from dual tone rf signal using a double stage voltage rectifier for wireless power transmission," in 2019 5th Intl. Conf. Advances Electrical Engineering (ICAEE). IEEE, 2019, pp. 757–762.
- [7] A. J. Islam, M. K. Hamid, S. S. Alam, M. M. Hasan, M. A. Hoque, and M. N. M. Rafid, "A greener approach to harvest energy using piezo-speed breaker," in 2019 Intl. Conf. Electrical, Computer Communication Engineering (ECCE). IEEE, 2019, pp. 1–4.
- [8] S. S. Alam, A. J. Islam, M. M. Hasan, M. N. M. Rafid, N. Chakma, and M. N. Imtiaz, "Design and development of a low-cost iot based environmental pollution monitoring system," in 2018 4th intl. conf. elec. eng. inform. & comm. tech. (iCEEiCT). IEEE, 2018, pp. 652–656.

- [9] N. A. Islam and S. Choi, "Compact folded dipole metasurface for high anomalous reflection angles with low harmonic levels," *Scientific Reports*, vol. 10, no. 1, pp. 1–13, 2020.
- [10] N. Al Islam and F. Arifin, "Design and performance measurement of a miniaturized implantable pifa antenna for biomedical applications," *AIUB Journal of Science and Engineering (AJSE)*, vol. 16, no. 1, pp. 61–68, 2017.
- [11] A. J. Islam, M. M. Farhad, S. S. Alam, S. Chakraborty, M. M. Hasan, and M. S. B. Nesar, "Design, development and performance analysis of a low-cost health-care monitoring system using an android application," in *2018 Intl. Conf. Innov. Science, Eng. Tech. (ICISSET)*. IEEE, 2018, pp. 401–406.
- [12] S. Bakogianni and S. Koulouridis, "A dual-band implantable rectenna for wireless data and power support at subghz region," *IEEE Trans. Antennas Propagation*, vol. 67, no. 11, pp. 6800–6810, 2019.
- [13] A. Iqbal, P. R. Sura, M. Al-Hasan, I. B. Mabrouk, and T. A. Denidni, "Wireless power transfer system for deepimplanted biomedical devices," *Scientific Reports*, vol. 12, no. 1, p. 13689, 2022.
- [14] S. Ding, S. Koulouridis, and L. Pichon, "Implantable wireless transmission rectenna system for biomedical wireless applications," *IEEE Access*, vol. 8, pp. 195 551–195 558, 2020.
- [15] J. Kim and Y. Rahmat-Samii, "Implanted antennas inside a human body: Simulations, designs, and characterizations," *IEEE Trans. Microwave theory techniques*, vol. 52, no. 8, pp. 1934–1943, 2004.
- [16] C. Sanchez-Fern ´andez, O. Quevedo-Teruel, J. Requena-Carri ´on, ´ L. Inclan-S ´anchez, and E. Rajo-Iglesias, "Dual-band microstrip patch antenna based on short-circuited ring and spiral resonators for implantable medical devices," *IET microwaves, antennas & propagation*, vol. 4, no. 8, pp. 1048–1055, 2010.
- [17] F. Merli, L. Bolomey, J.-F. Zurcher, G. Corradini, E. Meurville, and A. K. Skrivervik, "Design, realization and measurements of a miniature antenna for implantable wireless communication systems," *IEEE Trans. Antennas and propagation*, vol. 59, no. 10, pp. 3544–3555, 2011.
- [18] C. Liu, Y.-X. Guo, and S. Xiao, "Compact dual-band antenna for implantable devices," *IEEE Antennas Wireless Prop. Letters*, vol. 11, pp. 1508–1511, 2012.
- [19] L.-J. Xu, Y.-X. Guo, and W. Wu, "Miniaturized dual-band antenna for implantable wireless communications," *IEEE Antennas Wire. Propagation Letters*, vol. 13, pp. 1160–1163, 2014.