

<https://doi.org/10.33472/AFJBS.6.Si2.2024.3041-3050>



African Journal of Biological Sciences

Journal homepage: <http://www.afjbs.com>



Research Paper

Open Access

REVOLUTIONIZING ELECTRIC VEHICLES: RENEWABLE ENERGY INTEGRATION FOR ELECTRIC VEHICLES USING EMBEDDED SYSTEMS

¹Pathan Arshiya Banu, ²Dr D Chandra Sekhar

¹PG scholar, ²Professor

^{1,2}Dept of EEE, Vemu Institute of Technology, P Kothakota, Andhra Pradesh, India.

¹arshiyabanu441@gmail.com

Article History

Volume 6, Issue Si2, 2024

Received: 20 Apr 2024

Accepted : 05 May 2024

doi: 10.33472/AFJBS.6.Si2.2024.3041-3050

ABSTRACT

renewable energy (RE) and electric vehicles (EVs) were to gain traction, the transportation and power generation industries might significantly cut their carbon emissions. Electric vehicles' widespread adoption may pave the way for renewable energy sources like solar and wind to become more integrated into power grids. In this article, we review the research on how renewable energy, the grid, and electric vehicles interact with one another. There is an analysis of well-known research methods and theoretical frameworks. We look at how EVs will affect the electricity system, the environment, and the economy. The topic of electric vehicle integration has been extensively researched. According to research, there is a lot of space for improvement in power system optimization in order to reduce the excess of renewable energy. A "vehicle to grid" (V2G) connection allows plug-in electric cars (PEVs) to connect to an already-established power grid. The electrical grid's efficiency may be enhanced by using the V2G idea. Overall productivity, consistency, and reliability will all see significant improvements. search terms Renewable energy sources, electric cars, embedded systems, and the Arduino uno

I. INTRODUCTION

The transportation and energy sectors are at the heart of many of the most critical problems of the century, such as the peak of oil production, global warming, and the quest for energy independence. Sixty percent of the world's primary energy is used by the transportation and power sectors combined

[1]. For this reason, coal is often used. One example is the growing demand for environmentally friendly transportation options, such as electric automobiles, which aim to reduce oil use and carbon dioxide emissions. Developing and relocating fossil fuel energy—including

housing and deployment—reduced emissions of greenhouse gases and other pollutants, such as sulfur dioxide (SO₂) and nitrogen oxides (NO_x). An increasingly practical alternative is renewable electricity. We can potentially cut down on our reliance on fossil fuels (FF) and, by extension, our emissions of greenhouse gases, if we combine electric power with mobility and renewable energy (RE). Several obstacles make it difficult to integrate renewable energy sources into the grid on a large basis [2]. Regardless of changes in energy demand, renewable energy (RE) sources such as solar power and photovoltaic (PV) energy are consistently accessible.

II. EMBEDDED SYSTEMS

An embedded system is one that we developed specifically for a single purpose, allowing its software code to communicate with its underlying hardware. Hardware, which includes components like processors, ASICs, memory, etc., is used for performance, while software is utilized for offering functionality and flexibility. The digital information technology known as "embedded systems" is becoming pervasive in our daily lives. Even though they aren't seen by the consumer as "computers" in the traditional sense, more than 98% of processors used today are in embedded systems. When a computer is entirely contained inside or assigned to the specific device or system it operates, we say that it is an embedded system. When compared to a personal computer or other general-purpose computer, an embedded system is designed to carry out a single or limited set of

functions, sometimes with very particular needs. The system's optimization by design engineers allows them to decrease the product's size and cost by focusing on certain duties. Mass production allows embedded systems to take advantage of cost savings. One of the most significant changes in high-end embedded systems in the last several years is the growing reliance on PC technology. Thanks to this trend, high-end system hardware prices have plummeted, allowing for the realization of projects that were previously unfeasible due to the prohibitive cost of embedded hardware that is not PC-based. While the embedded PC platform's hardware options are appealing, the software possibilities are much less so. The majority of embedded systems employ a single microprocessor board with read-only memory (ROM) for software storage. Watches, microwaves, video game consoles, and even automobiles rely on embedded systems because of their digital interfaces. Although some embedded systems come with an OS, many are highly specialized to the point where all of the logic may be written in a single application. Embedded systems may be found in a wide variety of physical forms, from small, handheld devices like digital watches and MP3 players to massive, permanently installed systems like those regulating nuclear power plants, traffic lights, and factory controls. Embedded systems may be as basic as a single microcontroller chip or as complicated as a massive chassis or enclosure housing several modules, peripherals, and networks.

From streamlining deliverable goods to lowering research and manufacturing costs, the embedded computer system's adaptability makes it useful in many sorts of businesses. Special operating systems that consider key features of embedded systems are used by complex systems with extensive functionality. Because of their small footprint and potential adherence to real-time OS characteristics, embedded operating systems are becoming more popular. While embedded systems may be very powerful and complex, special-purpose computer systems are often less powerful than general-purpose systems.

III. LITERATURE REVIEW

Numerous critical problems plaguing the modern world have their origins in the transportation and energy sectors. Innovative technologies have been implemented into power systems in response to the current state of things and the aim to further decrease emissions. Energy must be generated from renewable and sustainable sources if we are to reach carbon neutrality and ensure a reliable and cheap supply. In order to continue moving towards an environmentally friendly and sustainable energy system, it is essential to speed up the process, reorganize major businesses like transportation, and construct the required infrastructure and governance [3]. Their popularity is on the rise due to the environmental advantages of electric cars. Forecasts indicate that the electric car industry will be worth \$457.60 billion by the year 2023. The port estimates that 16.21 million EVs will have been sold globally by 2027 [4]. Continuous efforts to improve vehicle

energy efficiency, particularly in relation to power consumption per unit distance, provide a significant challenge to the increasing greenhouse gas emissions caused by vehicle travel. Both new and improved vehicle technologies may enhance fuel efficiency[5,6], and [7] offers a comprehensive analysis of contemporary energy storage systems developed for use in vehicles. There have been many discussions on the need of energy independence, global warming, and EVs[7,8,9, 10]. More than 60% of the world's main energy supply is used by the transportation and electrical sectors [1]. For this reason, coal is often used. For instance, the development and relocation of fossil fuel production led to a decrease in greenhouse gas emissions as well as other pollutants such as sulfur dioxide (SO₂) and nitrogen oxides (NO_x). This has led to a surge in the popularity of electric cars as a means for people to reduce their impact on the environment from transportation. There has been a meteoric rise in the use of renewable energy. There is great potential for a dramatic decrease in the global reliance on fossil fuels (FF) and, therefore, greenhouse gas emissions via the integration of renewable energy (RE), transportation, and electricity. A lot of obstacles make it hard to integrate renewable energy sources extensively [2]. Solar and photovoltaic (PV) energy are examples of renewable energy sources that may be used continuously, regardless of fluctuations in power demand.

IV. EXISTING METHODS

Solar-Powered Charging Stations: Electric vehicle charging stations that use solar panels to provide power. Removes the need to use fossil fuels to charge electric vehicles by connecting them directly to renewable power sources.

Wind-Powered Charging Infrastructure: Combining electric vehicle charging stations with wind turbines to use wind power to charge electric vehicles. Even in areas with few sun resources, renewable energy may be produced using wind-powered charging stations.

The creation of intelligent charging algorithms that optimize the charging schedules of electric vehicles in response to changes in power costs, grid demand, and the availability of renewable energy sources. Reduces carbon emissions and grid pressure during peak demand by letting electric vehicles charge during times of strong renewable energy output.

Connecting Vehicles to the Grid (V2G): With the help of V2G technology, power may now flow in both directions from the grid to EV batteries. When renewable energy production is higher than demand, EVs will draw power from storage, and at times of high demand or low output, they will send power back to the grid.

Installing energy storage devices, such flow batteries or lithium-ion batteries, to electric vehicle charging stations to retain surplus renewable power is known as energy storage systems (ESS). ESS guarantees dependable EV charging regardless of fluctuations in renewable energy output and helps to reduce the challenges

related to renewable energy sources' intermittency.

Electric vehicles may now be charged using renewable energy sources when they are available and through grid power when they are required thanks to grid-tied EV charging. Maximizing the utilization of renewable energy, grid-tied charging guarantees that electric vehicle owners have access to dependable charging.

In places where grid connection is restricted or nonexistent, it is possible to install off-grid charging options for electric vehicles. To provide environmentally friendly charging choices, off-grid charging systems usually integrate energy storage with renewable power sources like solar panels or wind turbines.

Connecting electric vehicle charging stations to smaller power grids that are fueled by renewable energy is known as micro-grid integration. For electric vehicle charging, microgrids provide a solution for distributed renewable energy production and storage while also increasing energy resiliency.

The creation of feed-in tariffs, tax credits, and renewable energy requirements are examples of policies and laws that may be used to support the integration of renewable energy with electric vehicle charging.

Scans of legislative frameworks that are conducive to EV uptake and investment in renewable energy infrastructure are encouraging. Partnerships between public and private sectors, including utilities, electric vehicle (EV) makers,

and renewable energy (RE) providers, are known as public-private partnerships (PPPs).

IV. PROPOSEDSYSTEM

Vehicle and energy source:

All cars that use a rechargeable battery pack are referred to as electric vehicles (EVs). In order to generate mechanical energy, the engines of most ICEVs need fossil fuels such as gasoline or diesel. An extensive overview of the several EV-technologies that are either already in use or are seeing growth worldwide is given by Jorgensen [5]. A small electric battery drives the transmission mechanism in hybrid electric vehicles (HEVs), making the internal combustion engine more fuel efficient. A hybrid electric vehicle's battery may store energy produced by the engine and the vehicle's own motion. Fueled mostly by liquids, this vehicle achieves efficiency levels typical of HEVs. It's an advancement on the concept of a plug-in hybrid electric vehicle (PHEV) that makes use of an increased grid connection or battery capacity. The range on a single charge is increased with larger batteries, and the recharging process is accelerated with grid connection.

Connectivity to the grid and charging:

Connecting an electric vehicle to a standard wall socket at home may be done in a number of ways. The device starts charging the vehicle automatically when it is linked to the power grid, whether it's a normal or unlimited plan. For example, a three-hour delay has been imposed on the battery charging timetable. The procedure

starts again in the morning after the battery is charged at night, when energy is cheaper. Intelligent management of car charging is the responsibility of the utility or charging equipment owner or operator. Both direct and indirect charging are possible. It is recommended to use indirect charging, say Dallinger and Wietschel [6]. Power generation and the grid Networked device: A number of adapters are on the market that can be used to charge electric vehicles using regular wall outlets. Connecting a vehicle with a regular or unlimited charging plan will cause it to begin charging automatically. For example, a three-hour delay is now in effect for when batteries must be charged. The process starts again in the morning after the battery has been charged over the night, when power is cheaper. The people responsible for managing the charging infrastructure should make sure it's run as efficiently as possible for those who drive electric vehicles. Direct or indirect pricing is possible. According to Dallinger and Wietschel, indirect pricing works better in the box diagram.

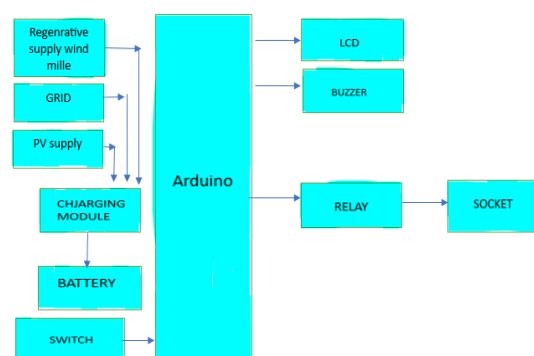

Figure 1: Block Diagram

V. SOFTWARE REQUIREMENTS

Arduino:

The open-source Arduino platform is a software and hardware environment for creating prototypes. It is comprised of a programmable circuit board (also called a microcontroller) and an Integrated Development Environment (IDE) called Arduino that is pre-made for writing and uploading code to the physical board. A wide variety of sensors may provide signals to Arduino boards, which can then convert those signals into an output—for example, powering a motor, an LED, a connection to the cloud, or anything else you might imagine. The Arduino IDE (also called "uploading software") allows you to control your board's functionalities by sending a set of instructions to the microcontroller on the board. To load fresh code into an Arduino, you don't need an additional piece of hardware called a programmer, unlike most earlier programmable circuit boards. An ordinary USB cord will do the trick. Another thing that makes learning to write with the Arduino IDE simpler is that it utilizes a stripped-down version of C++. Lastly, an easily digestible microcontroller package is provided by Arduino, which offers a standard form factor.

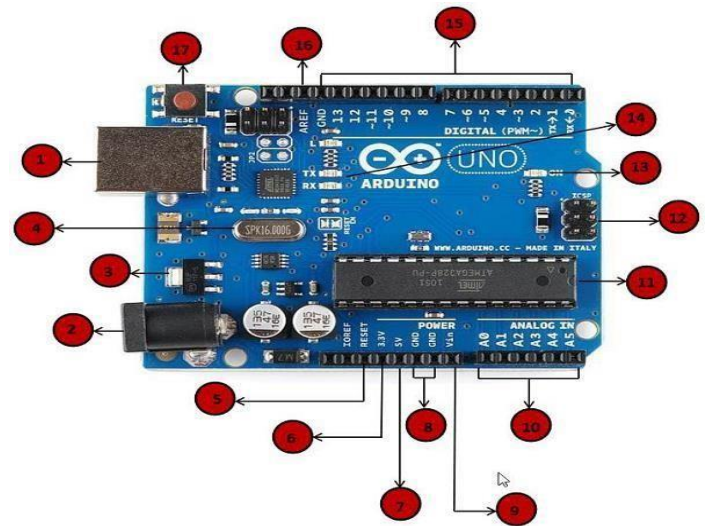

Figure 2: Arduino Uno

Before you upload the code to the board, make sure you understand what each icon in the Arduino IDE toolbar does.

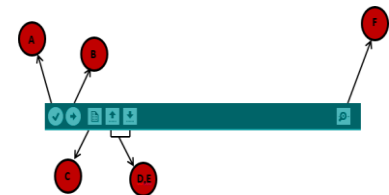

Figure 3: Upload the program to board.

The purpose of the A is to determine whether there is a compilation mistake.

The Arduino board may be programmed using the B- button.

The shortcut C is used to generate a fresh drawing. To open one of the sample sketches immediately, press D.

Pressing E will save your drawing. An F- serial monitor is used for receiving and

transmitting serial data from the board. The next step is to go to the environment and find the "Upload" button. Just give it a little while, and the board's RX and TX LEDs will start blinking. The status bar will display the message "Done uploading" if the upload is successful. we will study the structure of Arduino programs and get a better understanding of new terms used in the Arduino community. There is no cost to use the Arduino software since it is open-source. The C/C++ microcontroller libraries and the Java environment's source code are both available under the LGPL and GPL, respectively. "Sketch" is the name of the Arduino program, which is the first piece of new vocabulary. The three primary components of an Arduino program are the Structure, the Values (constants and variables), and the Functions. This lesson will teach you what you need to know about the Arduino software, including how to create code that doesn't have syntax or compilation errors.

LCD interface with Microcontroller:

When connecting an LCD to a microcontroller, the standard interface is either an 8-bit or 4-bit mode. A 4-bit mode is used in this project's LCD connection. Below are the connectors for the LCD interaction with the microcontroller:

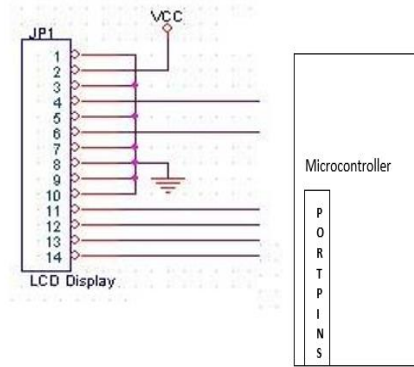

Figure 4: LCD Interface with Microcontroller

The following pins on the microcontroller are linked to the LCD: RS to p0.0, EN to p0.1, D4 to p0.4, D5 to p0.5, D6 to p0.6, and D7 to p0.7. In 8-bit mode, all control signals and the whole ASCII code are sent simultaneously. However, in 4-bit mode, the data is split into two halves, the upper nibble and the lower nibble, which are referred to as the MSB and LSB, respectively. Signals RS, R/W, and E are used for control. The internal registers, namely the data register and the command register, may be selected using RS. To switch between reading and writing on the LCD, press and hold the R/W button. To internally push data to the relevant registers, E is used as chip select. When transferring data or commands in 8-bit mode, after choosing the appropriate register and switching to write mode, the data is transferred to the 8-bit data bus. Next, the data is sent by sending a high-to-low signal to the E signal pin. The higher nibble is sent to the MSB of the data port first when transferring data or commands in 4-bit mode, and the E is given a high

to low signal. Following a brief pause or while the LCD is idle, the same process is repeated to transmit the lower nibble.

VI. EXPERIMENTAL RESULTS

Implementation process:

The project is a renewable energy charging station for electric vehicles; it allows the user to schedule when their car will be charged, stores solar energy in a battery, and selects the charging mode via a switch.



Figure 5: implementation

The vehicle starts charging when the timer runs out. In this setup, the Arduino interfaces with the LCD through lines 8, 9, 10, 11, 12, and 13 marked as rs, en, d4, d5, d6, and d7. The user can select the charging mode using the switches connected to A0 and A1, and then they can turn on the charging by selecting the relays connected to pins 7 and 6. This activates the charging process, which charges the battery. Alternatively, the vehicle can generate energy by spinning its wheels, as indicated briefly in Figure 2.

VII. CONCLUSION AND FUTURESCOPE

Conclusion:

Once the necessary infrastructure is put in place, electric vehicles (EVs) may help stabilize and enhance power grids, decrease emissions of carbon dioxide, and minimize operating costs. On the other hand, electric vehicles could wind up significantly helping with the grid integration of renewable energy sources. Power plants and ships may cut down on their carbon emissions if this were to happen. Even though EVs may assist with some of the issues with widespread RE, it's important to remember that other techniques and technologies will likely still be required to achieve the high level of RE penetration, even with EVs. One of the many ways electric cars might improve the grid is by making it easier to integrate renewable energy sources that provide electricity only when the system is not fully operational. You must be aware of the outcomes of this link in order to comprehend the implications of combining transportation, power, electricity, and renewable energy sources. Policy and infrastructure development must adjust to this new reality if we are to reap the economic and environmental advantages of technological innovation while lowering emissions of greenhouse gases and our reliance on fossil fuels. Everyone wins with PEVs: consumers, the car industry, and the planet. In the event of a power outage, plug-in hybrids or other PEVs outfitted with energy storage connectors, digital charger management software, and huge batteries may continue to provide electricity. It encourages more people to buy PEVs and is good

for the environment. Figure 2 shows the operation of the electric vehicle charging system, which is switch mode auto start and auto stop once the counting period ends.

Future scope:

To further improve the usage of renewable energy sources, we need to create smart charging algorithms that take grid demand, customer preferences, and the availability of renewable energy into account while optimizing EV charging schedules.

methods for deploying power to deal with the intermittent nature of renewable energy sources and provide consistent charging for electric vehicles.

2. Modernizing the system: Adding new features to the system, such as grid-scale energy storage, demand response programs, and protocols that make electric vehicle charging easier, in order to handle more renewable energy and EV charging. Thirdly, public-private partnerships (PPPs) bring together different sectors to pool resources and expertise in order to finance and execute renewable energy integration projects for electric vehicles. These partnerships include government agencies, utilities, automobile manufacturers, and producers of renewable energy.

4. Regulatory and policy innovation: creating new frameworks and rules to encourage the use of renewable energy for electric vehicle charging, such as performance-based incentives, cross-sector partnerships, and market-based procedures.

5. Global Collaboration: Encouraging global cooperation and the exchange of information in

order to hasten the worldwide implementation of renewable energy integration for electric vehicles by tackling shared obstacles and capitalizing on regional best practices. Finally, a key to attaining sustainable and low-carbon transportation is the combination of renewable energy with electric cars.

VIII. REFERENCES

- [1] Key World Energy STATISTICS,(2011), Paris: International Energy Agency.
- [2] G.Boyle, Renewable Electricity and the Grid: The Challenge of Variability, London: Earth scan Publications.
- [3] Harvey LDD, (2010), Carbon – Free Energy Supply, London: Earth scan.
- [4] Lund H, Kempton W, "Integration of renewable energy into the transport and electricity sectors through V2G".
- [5] K. Jorgensen, "Technologies for electric, hybrid and hydrogen vehicles: Electricity from renewable energy sources in transport," Elsevier.
- [6] Dallinger D, Wietschel M, "Grid integration of intermittent renewable energy sources using price responsive plug-in electric vehicles," Elsevier.
- [7] Lunz B, Yan Z,Gerschler J, SauerD, (2012), "Influence of plug-in hybrid electric vehicle charging strategies on charging and battery degradation costs," Elsevier.
- [8] KemptonW, LetendreS, "Electric vehicles as a new power source for

Pathan Arshiya Banu / Afr.J.Bio.Sc. 6(Si2) (2024)

electric utilities," Elsevier.

[9] D.S.P.Sukhatme, Book of "Solar Energy" ,

Tata Mc Graw Hill Publication.

Shruti Sharma, Kamlesh KumarJain,

Ashutosh Sharma, (2015), Solar Cells: In

Research and

Applications.